

# **KLAY-INSTRUMENTS**

## **INSTRUCTION MANUAL**

### **"INTELLIGENT" PRESSURE- AND LEVEL TRANSMITTERS**

#### **SERIES 2000-SAN SERIES 2000 SERIES CER-2000 SERIES 2000-HYDROBAR**

#### **WARNING**

Read this manual before working with the product. For personal and system safety and for optimum product performance, make sure you thoroughly understand the contents before installing, using, or maintaining the Series 2000, Series 2000-SAN, Series CER-2000 and the Series 2000-Hydrobar. Read the precautions and warnings on the last page.



**SERIES 2000**



**SERIES 2000-SAN**



**SERIES CER-2000**

Manufactured by:

 **KLAY-INSTRUMENTS**  
[www.klay-instruments.com](http://www.klay-instruments.com)

Nijverheidsweg 5  
P.O. Box 13  
Tel: +31 521-591550  
Fax: +31 521-592046

7991 CZ DWINGELOO  
7990 AA DWINGELOO  
The Netherlands  
E-Mail: [info@klay.nl](mailto:info@klay.nl)

## CONTENTS

SECTION		PAGE
<b>1</b>	<b>Introduction</b>	<b>3</b>
1.1	Description Series 2000-SAN	3
1.2	Description Series 2000	3
1.3	Description Series CER-2000	3
1.4	Description Series 2000-Hydrobar	3
1.5	Barometric reference	3
<b>2</b>	<b>Dimensions</b>	<b>4</b>
2.1	Dimensions Series 2000-SAN	4
2.2	Dimensions Series 2000	4
2.3	Dimensions Series CER-2000	4
2.4	Dimensions Series 2000-Hydrobar	5
2.5	Dimensions Series 2000-Hydrobar Junction box (G59)	5
<b>3</b>	<b>Installing Transmitter</b>	<b>6</b>
3.1	Installing Weld-on adaptor	6
3.2	Installing Series 2000-SAN	6
3.3	Installing Series 2000	6
3.4	Installing Series CER-2000	7
3.5	Mounting position	7
3.6	Mounting position effect	7
3.7	Installing Series 2000-Hydrobar	7
3.8	Calibration	7
3.9	Wiring	7
<b>4</b>	<b>Remaining</b>	<b>8</b>
4.1	Digital Local indicator	8
4.2	CE / EMC - Rules	8
4.3	External load	8
4.4	Intrinsically safe and Non Sparking (Ex)	9/10
4.5	Functional safety - SIL	10
4.6	Traceability year of manufacturing	10
4.7	Software revision	11
<b>5</b>	<b>Push buttons functions</b>	<b>11</b>
<b>6</b>	<b>Programming points (P101 - P114)</b>	<b>12</b>
<b>7</b>	<b>Reading on display</b>	<b>12</b>
<b>8</b>	<b>Explanation of programming points</b>	<b>13</b>
	P101 Zero adjustment (4 mA)	13
	P102 Span adjustment (20 mA)	13
	P103 Cancel mounting position effect	13
	P104 Pressure unit on display	14
	P105 Output: 4-20 mA or 20-4 mA	14
	P106 Damping adjustment	14
	P107 Process Temperature indication	15
	P108 Temperature °F or °C	15
	P109 Readout on Display	15
	P110 Simulation of current (4-20 mA)	15/16
	P111 Linearization	16/18
	P112 Density	18
	P113 Write protection	18/19
	P114 Response time from push buttons	19
	P115 Service-menu	19
	P116 Service-menu	19
<b>9</b>	<b>Programming of the Series 2000</b>	<b>20</b>
9.1	Programming with Hand Held Terminal	20
9.2	Programming with DTM	20
9.3	Programming with PDM	20
<b>10</b>	<b>Specifications</b>	<b>21</b>
<b>11</b>	<b>Precautions and warnings</b>	<b>22</b>
	<b>Attachment: EU-Declaration of Conformity</b>	<b>23</b>

## 1 INTRODUCTION

The Series 2000 and Series 2000-SAN are solid-state pressure- and level transmitters based upon a bridge resistive silicon sensor, with a very high burst pressure. The sensor element is mounted in a stainless steel foot. A very strong stainless steel "flush" diaphragm protects the sensor from the process medium. Special oil fills the chamber surrounding the sensor and transfers pressure from the flush mounted diaphragm to the sensor.

Pressure on the sensor element creates a very small deflection of the silicon substrate and bridge network. The resulting strain in the silicon resistors causes a change in the bridge resistance proportional to the pressure applied. The transmitter electronics detects this change in bridge resistance and converts it into 4-20 mA. The amplifier system is based on a single Integrated Circuit, which ensures a perfect linearity in the 4-20 mA output. Together with the **Klay flush diaphragm technology** the long term stability is perfect.

The Series CER-2000 are "All Stainless Steel" pressure transmitters based on a ceramic pressure cell, with very high burst pressure. These transmitters do not have oil filling.

The Series 2000, 2000-SAN and CER 2000 are available as SIL2, proven in use (Option G200).

### 1.1 DESCRIPTION SERIES 2000-SAN

The Series 2000-SAN are specially designed with a flush mounted diaphragm so they fully meet the needs of the food, pharma and chemical industries. The 2000-SAN series is available with the following sanitary standards:

- EHEDG.
- 3-A.

Standard the wetted parts are made of AISI 316, other materials are available, like Hastelloy C. Various process connections can be delivered, such as Tri-Clamp (1.5", 2" and 3"), SMS (1.5" and 2"), dairy milk couplings (DN 25, 40 and 50), flanges (DIN and ANSI) and sanitary weld-on adaptors (ø 1.89, 2.44 and 3.34 inch)

### 1.2 DESCRIPTION SERIES 2000

The Series 2000 is specially designed for the pulp and paper or similar industries, where clogging is a problem. The very compact construction of the Series 2000 permits flush installation with the tank or pipe wall. Standard the wetted parts are made of AISI 316, a lot of other materials are available.

All transmitters are fully temperature compensated, which means that various process temperatures have nearly no effect on the accuracy of the output signal. When a failure occurs, the transmitter is repairable. However, for optimum accuracy the transmitter has to be send back to the factory.

### 1.3 DESCRIPTION PERAMIC "S" (SERIES CER-2000)

The Series CER-2000 is a pressure transmitters based on a ceramic pressure cell, which can be used for all gauge and absolute pressure measurement on steam, liquids and gases. These transmitters **do not** have oil filling.

### 1.4 DESCRIPTION (SERIES 2000-HYDROBAR)

The Series 2000-Hydrobar is a complete range of submersible level transmitter for top mounting. The 2000-Hydrobar can be used in fluids like waste water, mud, pulp and chemicals. As standard the cable material is polyethylene. The connections for the wetted parts from the 2000-Hydrobar to the cable are from Viton® FKM.

### 1.5 BAROMETRIC REFERENCE

The Series 2000 is in basic a so called Relative Transmitter which means that barometric changes will not affect the zero (4 mA). The venting (4) is placed in the cover of the housing and is the barometric reference to atmospheric pressure. The venting must be kept clean.

**2 DIMENSIONAL DRAWINGS**

**2.1 SERIES 2000-SAN (CODE W)**

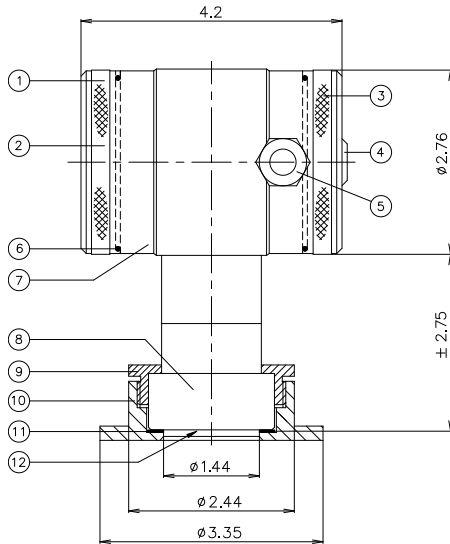

**PARTS**

- 1. Cover
- 2. Pushbutton + Display
- 3. Cover with venting
- 4. Venting
- 5. PG Cable gland
- 6. O-Ring (2 pcs)
- 7. Electronics housing
- 8. Foot
- 9. Lock ring
- 10. Weld-on Adaptor
- 11. Packing
- 12. Diaphragm

**MATERIAL**

- AISI 304
- AISI 304
- PA
- EPDM
- AISI 304
- AISI 316
- AISI 304
- AISI 316 L
- PTFE
- AISI 316 L

**2.2 SERIES 2000**

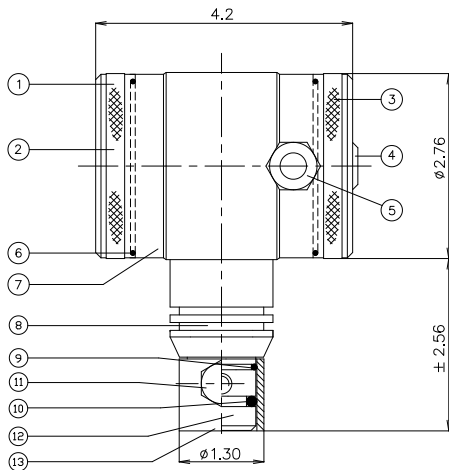

**PARTS**

- 1. Cover
- 2. Pushbuttons + Display
- 3. Cover met venting
- 4. Venting
- 5. PG Cable gland
- 6. O-Ring (2 pcs)
- 7. Electronics Housing
- 8. Foot with cooling fins
- 9. O-Ring
- 10. O-Ring
- 11. M8 bolt
- 12. Diaphragm and ring
- 13. Weldon adaptor  
 $\phi 1.3$  inch

**MATERIAL**

- AISI 304
- AISI 304
- PA
- EPDM
- AISI 304
- AISI 316
- Viton
- Viton
- AISI 316
- AISI 316
- AISI 316 L

**2.3 SERIES 2000**

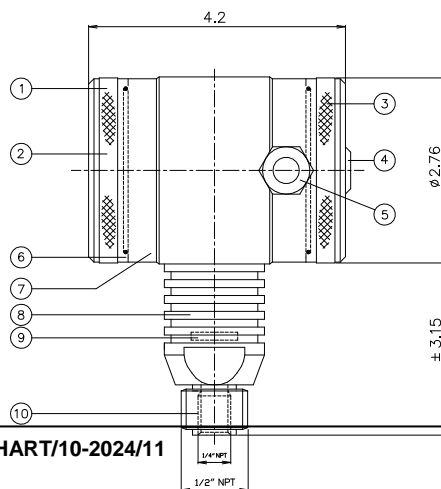

**PARTS**

- 1. Cover
- 2. Pushbuttons + Display
- 3. Cover with venting
- 4. Venting
- 5. PG Cable gland
- 6. O-Ring (2 pcs)
- 7. Electronics Housing
- 8. Foot with cooling fins
- 9. Ceramic sensor
- 10. Process connection  
1/2 " NPT

**MATERIAL**

- AISI 304
- AISI 304
- PA
- EPDM
- AISI 304
- AISI 316
- Al<sub>2</sub>O<sub>3</sub>
- AISI 316

A "Viton" O-Ring is used as standard for sealing the ceramic sensor. Other O-Ring materials are available on request. This depends on the process medium.

**2.4 SERIES 2000-HYDROBAR**

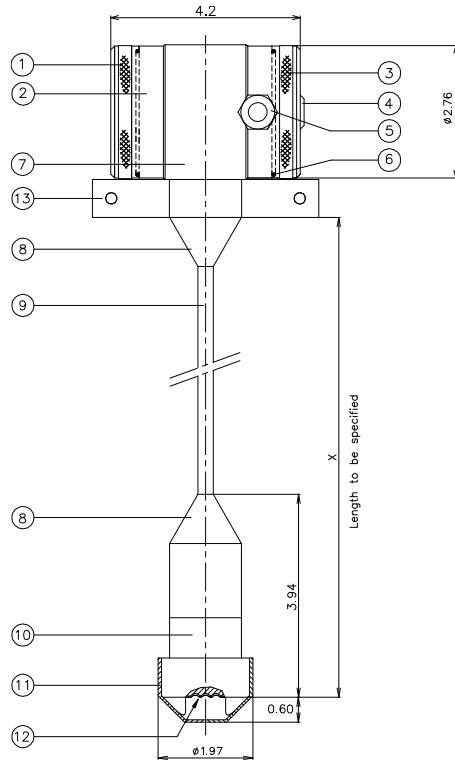

**PARTS**

**MATERIAL**

- |     |                                       |            |
|-----|---------------------------------------|------------|
| 1.  | Cover                                 | AISI 304   |
| 2.  | Pushbuttons + Display                 |            |
| 3.  | Cover met Venting                     | AISI 304   |
| 4.  | Venting                               | PA         |
| 5.  | PG Cable gland                        |            |
| 6.  | O-Ring (2 pcs)                        | EPDM       |
| 7.  | Electronics Housing                   | AISI 304   |
| 8.  | Connection to Cable                   | AISI 316   |
| 9.  | Cable with Venting                    | PE         |
| 10. | Sensor foot                           | AISI 316   |
| 11. | Diaphragm protection cap              | PE         |
| 12. | Diaphragm                             | AISI 316 L |
| 13. | Mounting bracket<br>(2 holes Ø 0.26") | AISI 304   |

The wetted parts of the 2000-Hydrobar are sealed with an O-Ring (Viton). Other materials can be applied (on request).

**2.5 SERIES 2000-HYDROBAR (JUNCTION BOX - G59)**

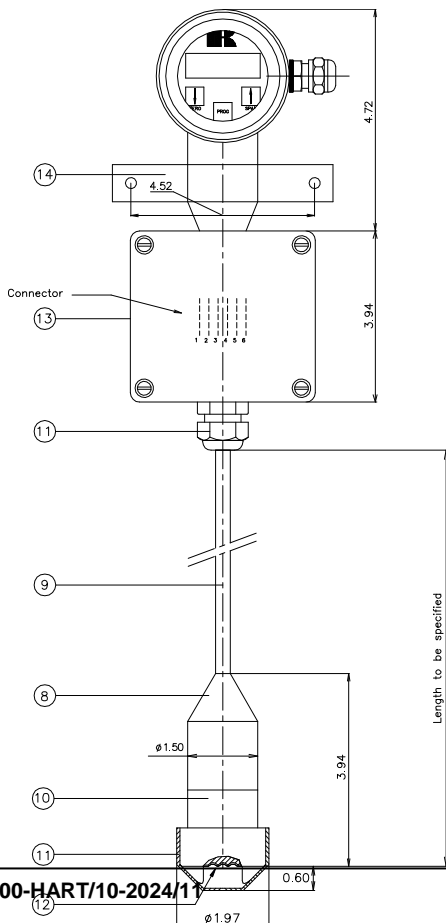

**PARTS**

**MATERIAL**

- |     |                          |           |
|-----|--------------------------|-----------|
| 8.  | Connection to Cable      | AISI 316  |
| 9.  | Cable with Venting       | PE        |
| 10. | Sensor foot              | AISI 316  |
| 11. | Diaphragm protection cap | PE        |
| 12. | Diaphragm                | AISI 316L |
| 13. | Junction Box             | AISI 316L |
| 14. | Mounting bracket         | AISI 304  |

The wetted parts of the 2000-Hydrobar are sealed with an O-Ring (Viton). Other materials can be applied (on request).

**3 INSTALLING TRANSMITTER**

The diaphragm of the transmitter is protected with a special protection cap. Protect the diaphragm until installation takes place. **DO NOT DAMAGE THE DIAPHRAGM**

**3.1 INSTALLING WELD-ON ADAPTOR**

A certified welder should perform installation of the weld-on adaptor. Weld with Argon, MIG or TIG. The smallest welding pin should be used.

1. Cut a hole in the process vessel/pipe to accept the weld-on adaptor. The hole should produce a tight fit when coupled with the weld-on adaptor.
2. Prepare the hole by beveling the edge to accept filler material.
3. Remove the weld-on Adaptor from the transmitter.
4. Remove the PTFE packing of the SERIES 2000-SAN.
5. **Remove the gasket and O-Ring out of the weld-on adaptor!**

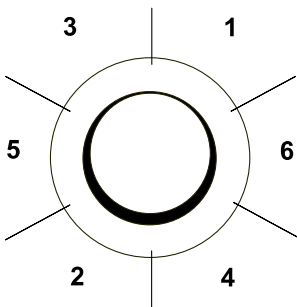

**WARNING**

Improper installation may result in distortion of the weld-on adaptor. Excessive heat will distort the weld-on adaptor. Weld in sections as shown in the figure left. Allow adequate cooling between passes. **To reduce the chances of distortion to the weld-on adaptor, use a mandrel.**

Series 2000-SAN Part.no. 1019  
Series 2000 Part.no. 1016

Determine (before welding) the position of the electronic housing, so that the cable entry and the venting are in the right position. After welding these positions are fixed.

6. Position the weld-on adaptor in the vessel hole and tack six places. The weld sequence is shown in the figure above.
7. Weld the weld-on adaptor in place using 0.03 to 0.045 inch. (0.762 to 1.143 mm) stainless rod as filler material in the beveled area. Adjust amperage for penetration.
8. Remove the mandrel after the welding operation.

**3.2 INSTALLING TRANSMITTER SERIES 2000-SAN**

1. Make sure to correctly locate the packing within the weld-on adaptor.
2. Improper installation of the packing can cause a process leak.
3. Position the transmitter into the weld-on adaptor and begin engaging threads.
4. The transmitter can be rotated prior to seating enabling the user to optimize access to calibration adjustments, cable entry, and local indicator.
5. Once the Lock ring (9) has been hand tightened, it must be tightened with an additional turn with adjustable pliers ( $\pm 1/8$ ").

**3.3 INSTALLING TRANSMITTER SERIES 2000**

1. After welding, clean up edges, and take care of the inside adaptor wall.
2. Make sure the O-Ring (10) and (11) are properly located. Improper installation at the O-Ring can cause a process leak.
3. Apply silicone grease to the O-Ring (10), diaphragm ring and the hole inside wall of the weld-on adaptor, this prevents galvanic cell corrosion between transmitter and Adaptor inside.
4. Install the transmitter and fix it with the AISI M8 bolt.

**3.4 INSTALLING TRANSMITTER SERIES CER-2000**

The position of the electronic housing is depending on the welding position of the weld-on adaptor. Before welding, locate the weld-on adaptor so that the cable entry and the venting are in the right direction. **DO NOT DAMAGE THE THREAD.**

**3.5 MOUNTING POSITION**

When the transmitter is mounted horizontally, the cable gland must be pointed downwards.

**3.6 MOUNTING POSITION EFFECT (Series 2000 and Series 2000-SAN)**

All transmitters are calibrated in vertical position. If the transmitter is mounted in another position, there can be a little zero shift. (4.02 mA instead of 4.00 mA). If the transmitter is mounted down, there is a zero shift (For example 3.98 mA instead of 4.00 mA). After installation of the transmitter the zero must be set to 4.00 mA with P103 in the programming mode. This will not affect the span.

**3.7 INSTALLING TRANSMITTER SERIES 2000-Hydrobar**

The diaphragms are protected by a special protection cap (PE). Do not remove this cap. When clogging is a problem, please contact Klay Instruments. Do not damage the diaphragm.

**3.8 CALIBRATION**

All transmitters are fully calibrated at the factory, to customer specified range. If calibration is not specified, the transmitter will be calibrated at the maximum span.

**3.9 WIRING**

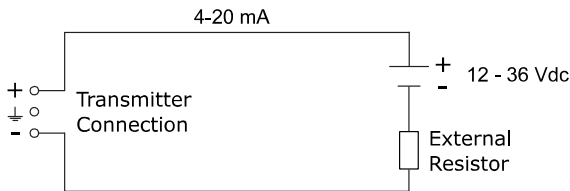

Under the cover (3) you will find the terminal board. The push buttons "Zero", "Span" and "Prog" are under the other cover (1). External loads must be placed in the negative side of the 2-wire loop.

The figure left shows the wiring connection of the transmitter. The 2-wires must be connected to 3 (-) and 4 (+) of the terminal board.

*The screw terminal tightening torque range needs to be: minimum 1.0 Nm (8.85 in-lb); max. 1,2 Nm (10.62 in-lb).*

*Remove approx. 5 cm (2 inch) of the cable mantle, strip approx. 1 cm (0.4 inch) of insulation from the ends of the individual wires. When using stranded cable apply the correct end sleeves for the wires and make sure these are connected properly underneath the screw terminals.*

*The field wire conductor cross-section needs to be: minimum 0,2 mm<sup>2</sup> (24 AWG) and maximum 1,5 mm<sup>2</sup> (16 AWG).*

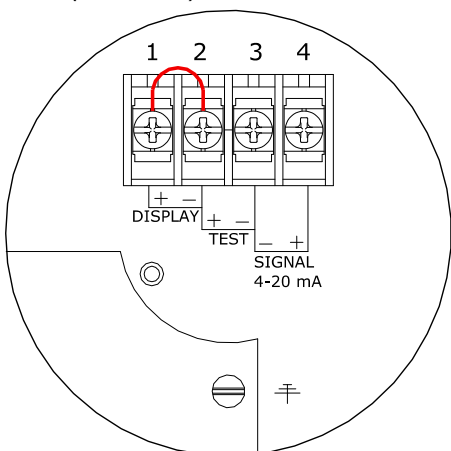

**The transmitter must always be connected to earth.** The transmitter must be connected with standard two-wire shielded cable. Do not run signal wiring in open trays with power wiring, or near heavy electrical equipment (Frequency controller or heavy pumps). Shielding must always be connected at the side of the power supply. In case the process connection is already connected to ground (e.g. via the tank or pipe line) **Do not** connect the instrument to ground. **Please ensure that the instrument is not connected to ground twice to prevent an 'earth loop'.** In applications with synthetic process connections, the enclosure (internal or external) must be connected to ground.

The CER-2000 with a synthetic process connection **must** be connected to earth. Reversing the polarity will not damage the transmitter, but the transmitter will not function until the + and - are properly connected.

4. REMAINING

4.1 DIGITAL LOCAL INDICATOR

All transmitters from the Series 2000 are standard equipped with a digital display. As standard transmitters are delivered with closed covers. The three push buttons and the display are behind the cover (1). As an option a Transparent cover can be delivered to achieve the display can be used as a local display in the process. The display can be set to any value between 0000 and 9999 (4 digit). (Option: "I" extra price).

4.2 CE / EMC - RULES

All Klay transmitters are manufactured in accordance with the RFI/EMC directives and comply with the CE standard. All transmitters are fitted with RFI filters, which provide optimum, trouble-free operation. Our products are in conformity with EMC-Directive 2014/30/EU based on test results using harmonized standards.

4.3 EXTERNAL LOAD

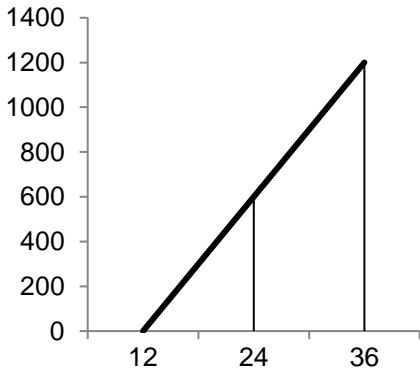

The minimum power supply is based on the total circuit resistance. The maximum permissible load (Ri max.) in case of 24 Vdc is 600 Ω (Ohm).

By increasing the power supply, the external load can be increased to 1200 Ohm / 36 Vdc. (see figure left).

$$Ri\ max = \frac{Power\ Supply - 12\ Vdc}{20\ mA}$$

 **With a loop resistance of 250 Ω a power supply of at least 17 Vdc must be used.**



**4.4 INTRINSICALLY SAFE and NON SPARKING (Ex version)**

The Series 2000, Series 2000-SAN, Series CER-2000 and Series 2000-Hydrobar-cable are also available for intrinsically safe (Zone 0). The Series 2000, Series 2000-SAN, Series 2000-Cable and Series 2000-SAN-Cable are also available for Non-Sparking (Zone 2).

**ATEX – DEKRA 20ATEX0025 X**

II 1G Ex ia IIC T4 Ga

II 2D Ex ib IIIC T100°C Db (*option G100, extra price*)

**IECEX – DEK 14.0079X**

Ex ia IIC T4 Ga

Ex ib IIIC T100°C Db (*option G100, extra price*)

Ex ec IIC T4 Gc (*option G180, extra price*)

**ATEX – DEKRA 20ATEX0026 X**

II 3G Ex ec IIC T4 Gc (*option G180, extra price*)

For detailed explanation see “EU-Declaration of conformity” on the last page of this manual.

**The transmitters with EPL Gc (option G180) shall only be used in an area of at least pollution degree 2.**

For use in a **non-sparking** area, the transmitter can be installed without the use of a (intrinsic safe) barrier. The transmitter can be connected with the following nominal value’s:

$U_N = 12...26.5$  Vdc;  $I_N = 4...20$  mA;  $P_N = 0,28$  W.

For use in an **intrinsically safe** area, use a certified power supply from 12 - 26,5 Vdc.

Installation of this device has to be carried out by a certified mechanic / installer.

Transmitter type and options	Equipment category	Ambient temperature range
Pressure / Level Transmitter Series 2000, Series 2000-SAN, Series 2000-Cable, Series 2000-SAN-Cable, Series CER-2000, Series 2000-Hydrobar-Cable and Series 2000-Hydrobar-EXTD  With transparent indicator cover (Option I)	II 1G	-20°C to +70°C (-4 to 158°F)  Process temperature range: -20°C to +100°C (-4 to 212°F)
Pressure / Level Transmitter Series 2000, Series 2000-SAN, Series 2000-Cable and Series 2000-SAN-Cable.  With closed covers, Option G180	II 3G	-20°C to +70°C (-4 to 158°F)  Process temperature range: -20°C to +100°C (-4 to 212°F)
Pressure / Level Transmitter Series 2000, Series 2000-SAN, Series 2000-Cable, Series 2000-SAN-Cable, Series CER-2000, Series 2000-Hydrobar-Cable, Series 2000-Hydrobar- EXTD and Temperature Transmitter Type TT-2000  With closed covers, Option G100	II 1G and II 2D	-20°C to +70°C (-4 to 158°F)  Process temperature range: -20°C to +100°C (-4 to 212°F)

The maximum surface temperature of IP6x enclosure T100 °C is based on a maximum ambient temperature of 70 °C (158°F) and maximum process temperature of 100 °C (212°F). This temperature is determined with a dust layer of maximum 5 mm (0.016 ft).

**Electrical Data**

Pressure / Level Transmitter Series 2000, Series 2000-SAN, Series 2000-Cable, Series 2000-SAN-Cable, Series CER-2000, Series 2000-Hydrobar-Cable, Series 2000-Hydrobar-EXTD and Temperature Transmitter Type TT-2000:

Supply/output circuit (terminals 3 ‘-’ and 4 ‘+’): in type of protection intrinsic safety Ex ia IIC, or Ex ia IIIC only for connection to a certified intrinsically safe circuit, with the following maximum values:  **$U_i = 26,5$  Vdc;  $I_i = 110$  mA;  $P_i = 0,9$  W (linear source);  $L_i = 1,4$  mH;  $C_i = 63$  nF** (without cable between terminals 3 ‘-’ and 4 ‘+’).

### Cable length

The maximum length of the cable for the Series 2000-Cable, 2000-SAN-Cable and 2000-Hydrobar-Cable is 100 m. Electrostatic charging of the cable and the protection cap by the flow of non-conductive media (for example in stirring vessels or pipes) shall be avoided.

### Special conditions for Safe use in Zone 0 and Zone 1

As category 1G equipment may be applied directly in the process, electrostatic discharge from the cable and the protection cap of Pressure / Level Transmitter Series 2000-Hydrobar-Cable by the flow of non-conductive media (for example in stirring vessels or pipes) should be avoided.

### Special Instructions for Safe use in Zone 2

For use in non-sparking areas (Zone 2), the following should be taken into consideration:

- As standard the transmitter is supplied **without** a certified cable gland. The cable entry is fitted with a PE blanking plug for protection during transport. Remove the blanking plug after installing the transmitter. When using a gland make sure it is **certified** and complying with applicable protection level of the transmitter.
- Always use the covers supplied by Klay Instruments B.V.
- All transmitters from Klay Instrument are designed to last for at least **10 years** under **normal** process and environmental conditions. The gaskets and seals for the Series 2000 are successfully tested according to IEC 60079-0 for temperature endurance (heat and cold), resistance to impact and ingress protection by DEKRA Certification. In harsh process and environmental conditions, the lifetime of gaskets and seals may be reduced. Klay Instruments strongly advises to inspect these yearly and replace them when necessary.

For use in a potentially explosive atmosphere caused by air/dust mixtures the following should be taken into consideration:

- The dust layer may not exceed a thickness of 5 mm.
- as standard a transmitter is supplied with a certified cable gland (PG). When using a different gland make sure it is certified and complying with applicable protection level of the transmitter.
- Always use the covers supplied by Klay Instruments B.V.

*All certifications are in compliance with IECEx scheme rules, and the International Standards: EN IEC 60079-0:2012, EN 60079-11:2012, IEC 60079-7:2015/ A1:2017, IEC 60079-11:2011 and IEC 17050-1:2010. The transmitters are certified for use in hazardous areas by DEKRA Certification.*



**DO NOT REMOVE THE SCREW COVER(S) WHEN AN EXPLOSIVE ATMOSPHERE MAY BE PRESENT.**

## 4.5 FUNCTIONAL SAFETY - SIL

The device is certified as “Proven in use” for a functional safety environment of SIL2 according to IEC-61511 and SIL1 according to IEC-61508.

*Note: Option SIL (Proven in use) is valid on transmitters with a serial number > 4309036, and only applicable with software version V9.17.*

When ordered as a SIL (Proven in use) transmitter, the safety manual will be supplied. (Option G200). Detailed information can be found in the Safety manual of the instrument. The most recent version of the Safety manual is available on: [www.klay-instruments.com](http://www.klay-instruments.com) under section Downloads.

## 4.6 TRACEBILITY YEAR OF MANUFACTURING

The year of manufacturing of the transmitter can be traced as follows: take the first two numbers from the serial number that is engraved in the transmitter and add 1970 to it.

For example: if the serial number is 4309036. The year of manufacturing is 1970 + 43 = 2013.

### 4.7 SOFTWARE REVISIONS

Due to the improvements on the Series 2000, there are several software versions (revisions). For this reason it is possible the transmitter you are working with does not support some options, which are discussed in this manual. This instruction is applicable from software version V9.17 and higher. After powering up, the transmitter will show the software version on the display.

### 5 PUSH BUTTONS FUNCTIONS

The Series 2000 can be programmed easily by use of the 3 front panel pushbuttons. The display can show engineering units of: mH<sub>2</sub>O(mWC), inH<sub>2</sub>O(inWC), bar and psi.

The functions of the three pushbuttons will be explained below.

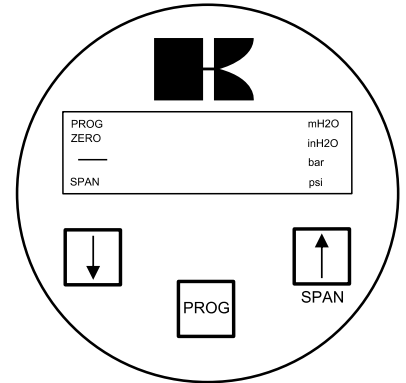

This button has 2 functions:

- It can be directly used for adjusting the zero (4 mA), with or without a test pressure. When the zero (4 mA) must be adjusted at 0 (atmospheric pressure), the button must be held until the word "Zero" appears on the display. The transmitter is now set to 4 mA.
- This button must be used for stepping down in the menu or to decrease a value (-).



**For canceling the mounting position effect you have to use P103.**



This button has 2 functions:

- It can be directly used for adjusting the span (20 mA), when using a test pressure (air). When a test pressure (e.g. 2 bar) is supplied to the transmitter, the button must be held until the word "SPAN" appears on the display. The transmitter is adjusted at 20 mA now. The span can also be adjusted without test pressure (see P102).
- This button must be used for stepping up in the menu or to increase a value (+).



This button has 2 functions:

- It is used to adjust the Programming Points (P101 till P114). Push it once and P100 is displayed, use the [↑] (SPAN) to step to P101.
- This button must also be used for confirming the adjustments (enter).

For example, if you want to change the adjustment in psi (P104), the following steps must be taken:

1. Push on [PROG] till "100" appears on the display.
2. Push on [SPAN] 4 times to go to point "P104" (adjustment pressure unit).
3. Push [PROG] to confirm this.
4. Push several times on [↑] (SPAN) to reach 3 (= bar). (Conversion table page 11).
5. 1 = mWC, 3 = bar, 5 = psi, 11 = inWC
6. Confirm this by pushing once at [PROG].
7. The transmitter is now adjusted to read in psi.

### 6. PROGRAMMING POINTS (P101 – P114)

The following points can be adjusted with the three push buttons. For an explanation of these points see the following pages of this manual.

To change one of these points you have to push on [PROG] until "100" appears on the display.

To go from a lower program (P101) to a higher one (P102), push on button [↑] (SPAN). To confirm the adjustments, you always have to press on [PROG].

\*) Standard adjustments ex works.

Programming points	
P101	Zero adjustment (4 mA)
P102	Span adjustment (20 mA)
P103	Cancel mounting position effect
P104	Adjustment pressure unit (See Conversion table)
P105	4-20 mA *) 20-4 mA (Reverse output)
P106	Adjustment damping (0 to 25 sec)
P107	Indication of process temp. (Read out on display)
P108	0 = °C (*) 1 = °F
P109	Read out on display: Curr (0) = Current (4 - 20 mA) (*) Unit (1) = Pressure unit (conversion table) PerC (2) = Percentage TenP (3) = Temperature Hect (4) = Hectoliters CBn (5) = Cubic meters Ltr (6) = Liters
P110	Simulation of current
P111	Linearization 0 = No Linearization (*) 1 = Cylindrical tank 2 = Vertical tank with cone 3 = Vertical tank with spherical cone
P112	Density
P113	Write Protection
P114	Response time from push buttons

### 7. READING ON THE DISPLAY

On the standard built-in display several values can be shown. When the transmitter is in the process the display gives all the information of the process pressure or temperature. On the display the following units are available: mH<sub>2</sub>O(mWC), inH<sub>2</sub>O(inWC), bar and psi (see P104 and P109).

PROG	mH <sub>2</sub> O
ZERO	inH <sub>2</sub> O
—	bar
SPAN	psi

The standard transmitter is supplied with two "closed" covers protecting the buttons and the display. As an option an "open" cover (IP 66) can be fitted. The display can then be used as a local process display. (Option: "I" extra price). The full scale can be set between -9999 and 9999 (4 digit).

8. EXPLANATION PROGRAMMING POINTS P101 to P114

P101

ZERO ADJUSTMENT (4 mA)

The transmitter as standard is adjusted to 4.00 mA at atmospheric pressure.

It is also possible to adjust a zero-suppression or elevation.

For example: Zero elevation of 1.45 psi.

1. Push at [PROG] until "100" is shown on the display.
2. Push once at [↑] / SPAN till "101".
3. Confirm this by pushing [PROG].
4. Now the display will show 0.00 mH<sub>2</sub>O. Push at [↑] till 1.45 psi is on the display.
5. Confirm with [PROG].
6. The output of the transmitter will be lower than 4 mA. The output at atmospheric pressure will be for example 3.68 mA. When a pressure of 1.45 psi is applied on the diaphragm the output will be 4.00 mA.

The elevation can be canceled by pushing at [↓] till zero disappears out of the display. The transmitter is now adjusted at 4 mA at atmospheric pressure.

P102

SPAN ADJUSTMENT (20 mA) WITHOUT TEST PRESSURE

Before adjusting the span take care the right pressure unit is selected.

(See also P104 and P109).

Example: Adjustment of the span at 0 - 29 psi.

First off all, the pressure unit must be adjusted at psi. (See P104).

1. Push [PROG] till "100" is shown on the display.
2. Push twice at [↑] / SPAN until "102" appears on the display.
3. Confirm this by pushing [PROG].
4. Push [SPAN] (+) or [ZERO] (-) to select the measuring range that is required.
5. Confirm by pushing [PROG].

The transmitter is adjusted now.



P102 is the adjustment of the total span.

When a compound range must be adjusted (for example -14.5 till +43.5 psi), a span of 58 psi must be programmed. The Zero (P101) must be set at -14.5 psi. The transmitter is adjusted at - 14.5 psi = Zero and +43.5 psi = Span.

If the process temperature at -14.5 psi is above 20 °C, another filling oil must be applied inside the transmitter (Option G26).

If the process temperature at -7.25 psi is above 60 °C, another filling oil must be applied inside the transmitter (Option G26).

P103

CANCEL MOUNTING POSITION EFFECT

All transmitters are calibrated vertically. When a transmitter of the Series 2000 or 2000-SAN is installed horizontally, there will be a small "mounting effect" on the zero (4 mA). For example, the transmitter shows 4.03 mA instead of 4.00 mA. This can be easily canceled with P103. In P103 there are three options:

**ESC** Nothing will be changed. Leave without doing anything. (confirm with PROG).

**RESET** Use this option when you are not sure if P103/SET has been done in a proper way. (confirm with PROG). When using this option, the original factory setting will be valid.

**SET** Canceling mounting position effect. (confirm with PROG). When SET selected the transmitter is automatically adjusted at 4.00 mA. Span will not be affected.



Do not apply pressure while executing "cancel mounting position effect"

**P104**

**ADJUSTMENT PRESSURE UNIT ON DISPLAY (See Conversion table)**

Several engineering units can be shown on the display by using a conversion factor. (See conversion table below). As standard the pressure unit of the transmitter is set to bar. Four engineering units can be used for displaying the applied pressure on the display (mH<sub>2</sub>O(mWC), inH<sub>2</sub>O(inWC), bar and psi).

1. Press [PROG] until "100" appears on the display.
2. Push 4x [↑] to get to point P104 (pressure unit setting).
3. Now press [PROG] to confirm this.
4. Now press [↑] or [↓] and set it to the correct pressure unit. See also the conversion table below. The number in brackets, see Display column, represents the menu options of transmitters with other software. Example:  
3 = bar
5. Then press [PROG] again to confirm. The transmitter is now set to read in "bar".

Conversion table:

	DISPLAY:	CONVERSIE FACTOR:
Meter water column	mWC or mwk (mH <sub>2</sub> O)	1.000
Millimeter watercolomn	mmWC or mmwk (mmH <sub>2</sub> O)	1000
Bar	bar	0.09806
Millibar	mbar (millibar)	98.0665
Pounds per square inch	psi	1.4223
Standard atmosfeer	atm	0.0967
Kilopascal	kPa	9.80665
Megapascal	MPa	0.009807
Kilogram vorce per square centimeter	kgf/cm <sup>2</sup>	0.1
Millimeter kwik	mmHg	73.556
Inch waterkolom	inWC (inH <sub>2</sub> O)	39.37
Inch Kwik	inHg	2.895906

To show one of the engineering units, P109 must be adjusted at 1 (= Pressure unit).

\*) Pressure units that can be shown on the display. When the value of the highest range is larger than 9999, "NA" will appear in the display (Not Applicable). Another unit must be chosen.

**P105**

**REVERSE OUTPUT (20 - 4 mA)**

The transmitter as standard is adjusted to 4-20 mA output.

Push on [PROG] and go to P105.

Push once at [↑] to change the output to 20-4 mA (Reverse output).

Push at [PROG] to confirm this.

Now the transmitter will give 20 mA at atmospheric pressure.

**P106**

**ADJUSTMENT DAMPING (0 ... 25 sec)**

In P106 an electronic damping can be adjusted between 0 and 25 seconds.

This can be done with the push buttons [↑] (up) and [↓] (down).

Always confirm by pushing once at [PROG].

**P107****INDICATION OF PROCESS TEMPERATURE (READ OUT ON DISPLAY)**

1. Push [PROG] until "100" is shown on the display.
2. Push 7 times at [↑], go to [P107].
3. Push [PROG] to confirm this. Now the process temperature appears on the display (Indication: +/-2°C).

This will remain on the display. To get the actual pressure back on the display you have to push again on P107 until the actual pressure appears on the display again.

**P108****TEMPERATURE IN °F OR °C**

The temperature of the transmitter is standard adjusted at °F (FAHR). When pushing at [↑] in P108, this will change into °C (CELC). Always confirm by pushing once at [PROG].

**P109****READ OUT ON DISPLAY**

Curr (0) = current	(4 - 20 mA)
Unit (1) = pressure unit	(See conversion table)
PErC (2) = percentages	(0 - 100%)
TEnP (3) = temperature	(°F or °C) <i>Indication of process temperature, accuracy depending on sensor position.</i>
hECt (4) = hectoliter	(only in combination with P111)
Cb n (5) = Cubic meter	(only in combination with P111)
Ltr (6) = Liters	(only in combination with P111)

As standard the transmitter read out is in mA (0). To change this, follow the next steps:

1. Push [PROG] until "100" is shown on the display.
2. Push 9 times at [↑] / SPAN till "109" appears on the display.
3. Confirm with [PROG].
4. Push once at [↑].
5. Push [PROG] to confirm this.  
The transmitter will now read mH<sub>2</sub>O (mWC).  
The pressure unit can be changed with the conversion table in P104.  
1 = mH<sub>2</sub>O (mWC), 3 = bar, 5 = psi, 11 = inH<sub>2</sub>O (inchWC).

The read out can also be in 0 - 100%. Select P109, option PErC (2).

**P110****SIMULATION OF CURRENT (4-20 mA)**

The transmitter can be used as a simulator of a current between 4 - 20 mA. This can be done in P110 with the push buttons [↑] and [↓].

The user can perform a current simulation (Curr) or a pressure simulation (Unit).

**Current-simulation (Curr)**

To perform a current-simulation follow the next steps:

1. Push [PROG] until "100" is shown on the display.
2. Push 10 times at [↑] / SPAN till "110" appears on the display.
3. Confirm with [PROG].
4. The display will readout 'Curr'
5. Confirm with [PROG].
6. The display shows '4.00'. Push [PROG] and the output changes to 4.00 mA.
7. By pushing [↑] / SPAN or [↓] / ZERO, you can change the value on the display. The output value will change as soon as the [↑] / SPAN OR [↓] / ZERO button is released.
8. Pressing the [PROG]-button again will exit the simulation.

**Pressure-simulation (Unit)**

To perform a pressure-simulation follow the next steps:

1. Push [PROG] until "100" is shown on the display.
2. Push 10 times at [↑] / SPAN till "110" appears on the display.
3. Confirm with [PROG].
4. The display will readout 'Curr'
5. Press [↑] / SPAN once
6. The display will readout 'Unit'.
7. Confirm with [PROG].
8. The display shows a pressure value. Push [PROG] and the output changes to a mA-output corresponding with the range entered in menu P101 and P102.
9. By pushing [↑] / SPAN or [↓] / ZERO, you can change the value on the display. The output value will change as soon as the [↑] / SPAN OR [↓] / ZERO button is released.
10. Pressing the [PROG] button again will exit the simulation.

The values that can be entered using the pressure-simulation are related to the adjustments in menu P101 and P102. These values are also the minimum and maximum values.

HART: This menu will not work when the device is operating in multi-drop mode.

**P111**

**LINEARIZATION**

- nLin (0) = No Linearization
- hCil (1) = Cylindrical tank (horizontal)
- ConU (2) = Tank with bottom cone
- SPHE (3) = Tank with spherical bottom

*Not possible in combination with Ex, G100, G180, G104 and G200.*

As standard the transmitter is delivered without Linearization nLin (= 0). However, for a horizontal tank or a tank with a bottom cone, a linearization can be applied to achieve the current signal (mA) is equal to the level in the tank. All values must be programmed in meters.

**Linearization horizontal tank (Cylindrical)**

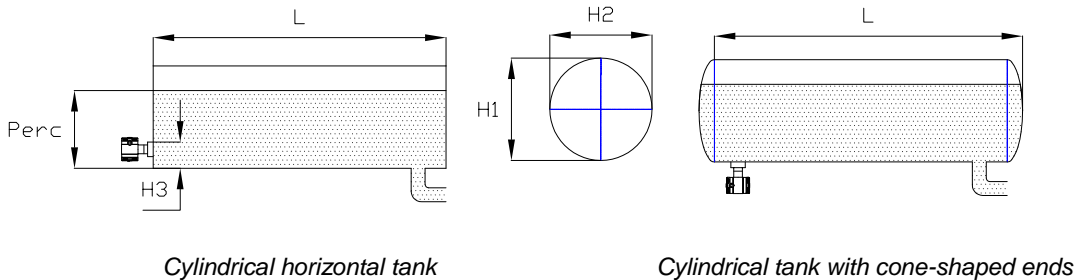

1. Push [PROG] until "100" is shown on the display.
2. Push 11 x at [↑] / SPAN till "111" appears. (Confirm with [PROG])
3. Push [↑] once. (Confirm with [PROG])
4. Enter the height (H1) of the tank in meters. (Confirm with [PROG])
5. Enter the same height (H2) of the tank in meters. (Confirm with [PROG])
6. Enter the length (L) of the tank. For a "ball" or cone shaped tank, take the cylindrical length plus the length of 1 "ball" cone. (Confirm with [PROG])



- 7. Enter H3 in meters if the transmitter is installed like in the left picture. Enter 0m when the transmitter is installed like in the right picture.
- 8. Enter the percentage of the actual "full" level (for example 80%). (Confirm with [PROG]).

**Linearization horizontal tank (Elliptic)**

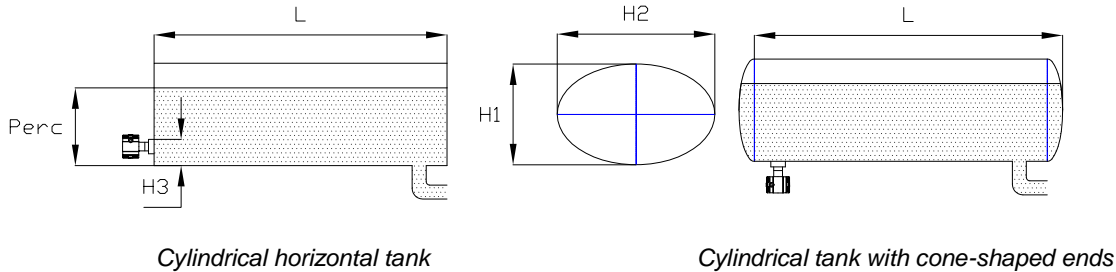

- 1. Push [PROG] until "100" is shown on the display.
- 2. Push 11 x at [↑] / SPAN till "111" appears. (Confirm with [PROG])
- 3. Push [↑] once. (Confirm with [PROG])
- 4. Enter the height (H1) of the tank in meters. (Confirm with [PROG])
- 5. Enter the height (H2) of the tank in meters. (Confirm with [PROG])
- 6. Enter the length (L) of the tank. For a "ball" or cone shaped tank, take the cylindrical length plus the length of 1 "ball" cone. (Confirm with [PROG])
- 7. Enter H3 in meters if the transmitter is installed like in the left picture. Enter 0m when the transmitter is installed like the right picture.
- 8. Enter the percentage of the actual "full" level (for example 80%). (Confirm with [PROG]).

*If the height (H) of the tank is 1 meter and the maximum level in the tank is 0.8 meter the percentage (point 8) must be set at 80%. The calibration at P102 must be adjusted at: 1 meter (if specific gravity equals 1).*

**Linearization vertical tank with cone**

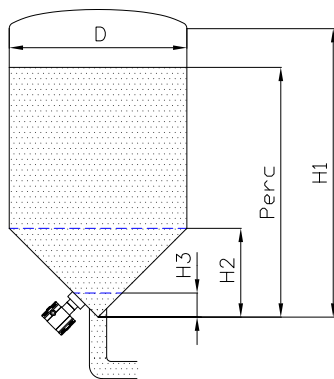

- 1. Push [PROG] till "100" appears on the display.
- 2. Push 11 times at [↑] till "111" appears.
- 3. (Confirm with [PROG])
- 4. Push twice at [↑]. (Confirm with [PROG])
- 5. Enter height (H1) of the tank (= actual level). (Confirm with [PROG]).
- 6. Enter diameter (D) of tank. (Confirm with [PROG])
- 7. Enter height (H2) of cone. (Confirm with [PROG])
- 8. Enter the height (H3) from the bottom of the tank to the topside of the diaphragm (or weld-on adaptor). (Confirm with [PROG]).
- 9. Enter the percentage of the actual "full" level (for example 80%).(Confirm with [PROG]).

Linearization vertical tank with spherical cone

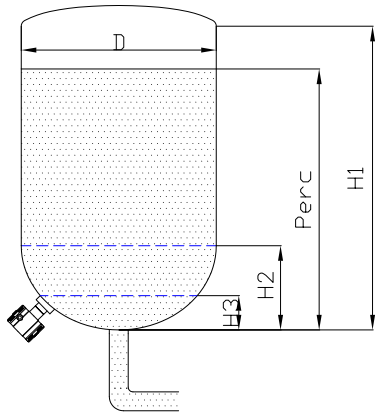

1. Push [PROG] till "100" appears on the display.
2. Push 11 times at [↑] till "111" appears.
3. (Confirm with [PROG])
4. Push three times at [↑]. (Confirm with [PROG])
5. Enter height (H1) of the tank (= actual level). (Confirm with [PROG]).
6. Enter diameter (D) of tank. (Confirm with [PROG])
7. Enter height (H2) of cone. (Confirm with [PROG])
8. Enter the height (H3) from the bottom of the tank to the topside of the diaphragm (or weld-on adaptor) (Confirm with [PROG]).
9. Enter the percentage of the actual "full" level (for example 80%).(Confirm with [PROG]).

When the specific gravity of the fluid is unequal to 1 and you do not want to use option P112, you must take care of defining of the **calibration** of the transmitter. Calibration (see P102) = Height of the level x Specific Gravity.

P112

DENSITY MEDIUM

If the specific gravity of the medium differs from 1 kg/dm<sup>3</sup>, you can enter the real density of the medium in option P112. Before this option is used, in menu P102 the 'true' height of the tank must be entered first.

P113

WRITE PROTECTION

The Series 2000 with HART-Protocol can be protected for adjustment (Write Protection). This is possible for two kinds of adjustments:

- Local changes with pushbuttons and display (L.Pro = Local Protection).
  - Changes by external HART configuration software (Handheld terminal or PC). (C.Pro. = Communication Protection).
- As standard, the transmitter is set to no-write protection.

Adjustment Local Protection

1. Push [PROG] till "100" appears on the display.
2. Push [↑] / SPAN 13 times till "113" appears on the display.
3. Push [PROG] to confirm. ("L.Pro." appears on the display).
4. Push [↑]/[↓] for adjusting to "ON" or "OFF".
5. Push [PROG] to confirm.

Adjustment Communication Protection

1. Push [PROG] till "100" appears on the display.
2. Push [↑] / SPAN 13 times till "113" appears on the display.
3. Push [PROG] to confirm. ("Lo.Pr." appears on the display).
4. Push once more at [PROG]. ("Co.Pr." appears on the display).
5. Push [↑]/[↓] for adjusting to "ON" or "OFF".
6. Push [PROG] to confirm.

When Lo.Pr. is set to ON, the display shows PROT for program point: 104, 105, 107, 108, 109 and 111. Both protections can be adjusted at the same time, independent from each other.

**P114**

**RESPONSE TIME FROM PUSH BUTTONS**

The response time from the push buttons can be adjusted from 0.0 till 5.0 seconds. The reaction time is set to 0.5 seconds from the factory.

**PROGRAMMAPUNT P115 & P116: SERVICE MENU**

Please consult manufacturer before using.

**9. PROGRAMMING THE SERIES 2000**

 When using HART® or a Hand Held Terminal (HHT), a minimum resistance of 250 ohms **must** be present in the loop of the 2-wire system. This is necessary for proper communication (see drawing below). A power supply of at least **17 Vdc** must be used.

**9.1 PROGRAMMING WITH THE HAND HELD TERMINAL**

The Series 2000 can be easily programmed with the Hand Held Terminal (HHT) from the "HART Foundation" or the HHT from "Rosemount" (type 275 or 375 Hart Communicator).

*Option 1: HART® Handheld terminal connected across the transmitter.*

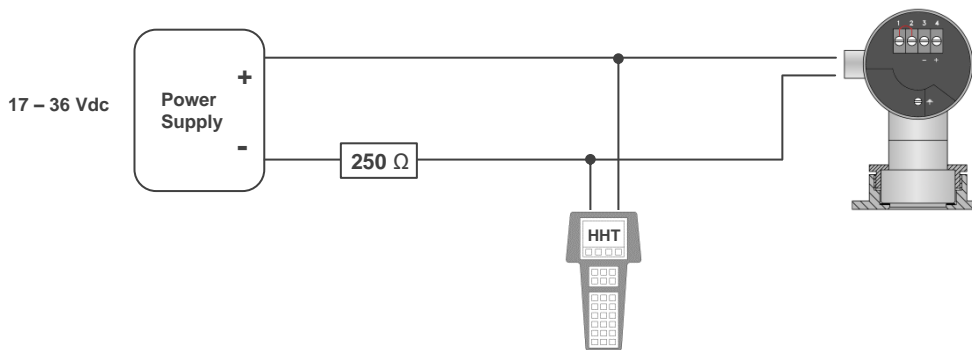

*Option 2: HART® Handheld terminal connected across the loop resistor.*

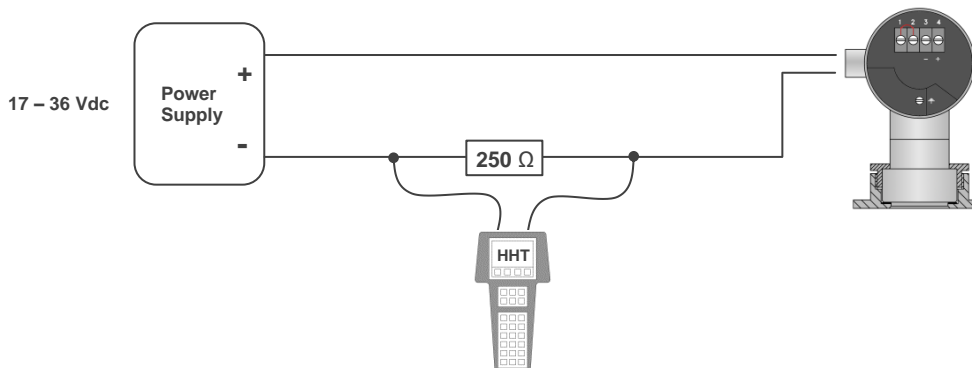

**9.2 PROGRAMMING WITH DTM**

An instruction manual is available which is a guide for installing and using the Klay Series 2000 HART DTM. This DTM is developed to make configuration changes of Klay Series 2000 HART transmitters easy. This DTM can be used with almost every FDT-container. The most recent version of the DTM file (zip file) is available on: [www.klay-instruments.com](http://www.klay-instruments.com) under section "Downloads". Unzip the file and run the installation.

### 9.3 PROGRAMMING WITH PDM

There is also a Device Description (DD) available for the Series 2000 HART. This DD can be used for configuring a Series 2000 HART transmitter using Simatic PDM. The most recent version of the DD file (zip file) is available on: [www.klay-instruments.com](http://www.klay-instruments.com) under section "Downloads". Unzip **KLAY\_PDM\_HART\_REV8.zip** and run DeviceInstall.exe.

## 10. SPECIFICATIONS

<i>Manufacturer</i>	Klay Instruments			
<i>Instrument</i>	Series 2000, Series 2000-SAN, Series CER-2000 and 2000-Hydrobar			
<i>Output</i>	4-20 mA Optional: HART® Protocol			
<i>Power Supply</i>	<b>Standard :</b> 12 – 36 Vdc <b>Ex :</b> 12 – 26.5 Vdc <b>HART® :</b> 17 – 36 Vdc (Standard) <i>min. 250 Ω</i> 17 – 26.5 Vdc (Ex) <i>min. 250 Ω</i>			
<i>Accuracy</i>	0.1% of adjusted span			
<i>Ranges</i> <sup>1</sup>	<b>Code</b>	<b>Adjustable span ranges</b>		<b>Max. overpressure</b>
Series 2000  Series 2000 (SAN)/2000-Hydrobar  Series CER 2000  Series 2000	1	0 - 1.45 psi	0 - 5.8 psi	93 psi
	2	0 - 4.35 psi	0 - 17.4 psi	150 psi
	3	0 - 14.5 psi	0 - 145 psi	435 psi
	4	0 - 72.5 psi	0 - 435 psi	1450 psi
	5	0 - 290 psi	0 - 1450 psi	2900 psi
	1	0 - 0.58 psi	0 - 5.8 psi	93 psi
	2	0 - 1.74 psi	0 - 17.4 psi	150 psi
	3	0 - 14.5 psi	0 - 145 psi	435 psi
	4	0 - 72.5 psi	0 - 435 psi	1450 psi
	5	0 - 290 psi	0 - 1450 psi	2900 psi
	1	0 - 2.9 psi	0 - 5.8 psi	93 psi
	2	0 - 11.6 psi	0 - 17.4 psi	150 psi
	3	0 - 29 psi	0 - 145 psi	435 psi
	4	0 - 145 psi	0 - 435 psi	1450 psi
	5	0 - 580 psi	0 - 1450 MPa	2900 psi
6	0 - 2175 psi	0 - 5800 psi	8700 psi	
	<sup>2</sup>	High pressure	(Option G83)	> 8700 psi
<i>Process Temperature</i> <sup>3</sup>	Series 2000	-4 °F to 176 °F		
	Series 2000 (SAN)	-4 °F to 212 °F		
	Series CER-2000	-4 °F to 212 °F (only gases)		
	Series 2000-Hydrobar	+10 °F to 160 °F		
<i>Ambient Temperature</i>	-4 °F to 158 °F (-20 tot 70°C)			
<i>Damping</i>	0.0 sec. till 25 sec. Standard damping: 0.0 sec.			
<i>Protection grade</i>	IP66 IP68 (2000-Hydrobar-Cable 'submersed parts')			
<i>Material</i>	Housing	AISI 304 (Optional AISI 316)		
	wetted parts	AISI 316 L (Other materials on request)		

<sup>1</sup> For vacuum applications/compound ranges in combination with higher process temperatures a special oil filling must be applied (Option G26).  
<sup>2</sup> For pressures higher than order code 6, Contact Klay Instruments for information.  
<sup>3</sup> For higher temperatures use other kind of pressure transmitters. Contact Klay Instruments for information.

**11. PRECAUTIONS and WARNINGS**

- *Check if the specifications of the transmitter meet the needs of the process conditions*
- *When the Series 2000-SAN is used as a level transmitter, be aware of the place where the transmitter is mounted. Here are some suggestions:*
  1. *DO NOT mount a level transmitter in- or near filling or discharging pipes.*
  2. *In case of automatic cleaning systems or hand cleaning: never point the water jets on the diaphragm, take necessary steps to avoid this. Guarantee will not be granted.*
- *When the Series 2000 is used as a pressure transmitter, be aware of the following points:*
  1. *Rapid closing valves in combination with high flow velocity will cause water hammer(spikes) and can destroy the transmitter. DO NOT mount a transmitter near such valves, always a few pipe bends away up or down stream (avoid suction).*
  2. *Install a pressure transmitter a few pipe bends away from pumps, as well on the suction or pressure side of the pump*

**WELDING INFORMATION:**

*When using the Series 2000 or 2000-SAN code "W" the welding information on page 4 must be followed exactly. This is very important to prevent distortion of the weld-on adaptors. It also prevents the screw thread from the Series 2000-SAN from being deformed.*

- *The diaphragm of the transmitter is protected with a special protection cap. Protect the diaphragm until installation takes place, to prevent damaging of the diaphragm.*
- *As soon as the wiring is brought inside through the PG9 cable gland and connected to the terminal board, make sure the cable gland is tightly fixed, so that moisture cannot enter into the electronic housing.*
- *Avoid high pressure water-jets pointed at the venting.*
- *If the ambient conditions are very wet, we advise to use a venting through the cable. A special vented cable can be delivered on request. (The normal venting will be removed)*
- *The covers must be fully engaged, so that moisture cannot ingress into the electronic housing. The covers must only be capable of being released or removed with the aid of a tool.*
- *Warranty is 1 year from delivery date.  
Klay Instruments does not accept liability for consequential damage of any kind due to use or misuse of the Series 2000. Warranty will be given, to be decided by the manufacturer. Transmitter must be shipped prepaid to the factory on manufacturers authorization.*
- *Klay Instruments reserves the right to change its specifications at any time, without notice. Klay Instruments is not an expert in the customer's process (technical field) and therefore does not warrant the suitability of its product for the application selected by the customer.*

**Manufactured by:**



Nijverheidsweg 5  
P.O. Box 13  
Tel: +31-521-591550  
Fax: +31-521-592046

7991 CZ DWINGELOO  
7990 AA DWINGELOO  
The Netherlands  
E-mail: [info@klay.nl](mailto:info@klay.nl)

Attachment: EU-Declaration of Conformity

# EU-DECLARATION OF CONFORMITY (no 01-2023-12)



**Klay Instruments B.V.**

Nijverheidsweg 5, 7991 CZ Dwingeloo, The Netherlands

**Certify that the equipment intended for use in potentially explosive atmospheres, only new products, indicated here after:**

Electronic Pressure / Level Transmitter Series 2000, Series 2000-SAN, Series 2000-Cable, Series 2000-SAN-Cable, Series CER-2000 and Series 2000-Hydrobar-Cable, Series 2000-Hydrobar-EXTD, Hydrobar-I-Cable and Temperature Transmitter Series TT-2000.

Are in accordance with:

- *Directive 2014/34/EU (Equipment and protective systems for use in potentially explosive atmospheres)*  
EN 60079-0: 2018 (General rules)  
EN 60079-7: 2015/ A1:2018 (Equipment protection by increased safety "e")  
EN 60079-11: 2012 (Equipment protection by intrinsic safety "i")
- *Directive 2014/30/EU (Electro Magnetic Compatibility -> EMC).*  
EN 55032:2016  
Lloyds Register Type Approval System and DNV Rules 2.4  
E10 – Test Specification for type Approval (REV7) (only EMC tests)  
IEC 61000-6-2: 2016 (EMC, Immunity in industrial location)  
IEC 61000-6-3: 2006+AMD1:2010 (EMC, Immunity in industrial location)  
IEC 61000-6-1: 2019 (EMC, Emission in industrial location)  
IEC 61000-6-4: 2018 (EMC, Emission in industrial location)  
IEC 61000-6-5: 2015 (zone 2) (EMC, Emission in industrial location)

The type (protection mode Intrinsic Safety "ia", "ib" and Non-sparking "ec") which has been the subject of; **EU-type Examination, Certificate Number:**

- **ATEX-DEKRA 20ATEX0025 X.**

Delivered by the DEKRA, Meander 1051, 6825 MJ Arnhem, The Netherlands, Notified Body No. **0344.**

**Type Examination, Certificate Number:**

- **ATEX-DEKRA 20ATEX0026 X.**

Date: September 14<sup>th</sup>, 2022.

E. Timmer

Managing Director – Klay Instruments B.V.

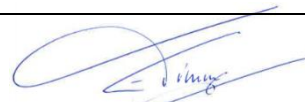
 (signature)

	The marking of the equipment for gas group for use in zone 0: <b>II 1 G Ex ia IIC T4 Ga</b>
	The marking of the equipment for dust group for use in zone 1: <b>II 2 D Ex ib IIIC T100°C Db</b>
	The marking of equipment for gas group for use in zone 2: <b>II 3 G Ex ec IIC T4 Gc</b>

- II equipment for use in industries above ground (and not in mines endangered by firedamp).
- 1 equipment for use in Zone 0 (if G), Zone 20 (if D).
- 2 equipment for use in Zone 1 (if D), Zone 20 (if D).
- 3 equipment for use in Zone 2
- G equipment for use with gas, vapours or mists
- D equipment for use with dust
- Ex equipment in compliance with European standards for explosive atmospheres
- ia equipment in compliance with specific building rules for intrinsically safe equipment
- ib equipment in compliance with specific building rules for intrinsically safe equipment
- ec equipment in compliance with specific building rules for non-sparking safe equipment
- IIC equipment for use with gas of subdivision C
- IIIC equipment for use in places with conductive dust.
- T4 equipment whose surface temperature does not exceed 135°C with < 70°C Ambient temperature.
- T100°C maximum surface temperature of the equipment covered with a dust layer of 5 mm

Ingress Protection Grade, Series 2000, 2000-SAN, CER-2000: **IP 66**

Ingress Protection Grade, Series 2000-Hydrobar-Cable and 2000-Hydrobar-EXTD: **IP 66**

**The Hydrobar-I-Cable and all other submersible parts from the Series 2000-Hydrobar, 2000-Cable and 2000-SAN-Cable are IP 68.**

Furthermore, whatever the protection mode, only use cable glands with a protection degree of at least IP 66.

Be sure the cable diameter complies with the selected cable gland. Tighten the cable gland in a proper way.

Never forget to mount the covers of the electronics housings in a proper way.

***For other technical details, refer to the instruction manuals of the transmitters.***