

INSTRUCTION MANUAL

KMW-LC

Level switch with hygienic process connection



*Read the installation recommendations and warnings of this manual.
For personal safety and optimal use, these instructions must be studied carefully.*

Manufactured by:

 **KLAY-INSTRUMENTS B.V.**

www.klay.nl

Nijverheidsweg 5
P.O. Box 13
Tel: +31 521 591550
Fax: +31 521 592046

7991 CZ DWINGELOO
7990 AA DWINGELOO
The Netherlands
E-mail: info@klay.nl

DESCRIPTION KMW-LC

The KMW-LC is a microprocessor controlled level switch with an integrated interface. The measurement is done using high-frequency waves. A great advantage of the KMW-LC is the possibility for trending. The process can be monitored over time, and the switch point can be set. The KMW-LC is very suitable as a level switch for monitoring liquids in hygienic applications. The KMW-LC is also very suitable for oil-like and viscous medium. The capacitive switch has a 316L housing and PEEK (FDA conform) process part. The switching status is very clearly visible through a unique LED indication (green) on the M12 cable entry.

INSTALLATION

The KMW-LC must be installed in the process using a sanitary weld-on nipple or adapter.

- LZN - Hygienic Weld-on nipple
- LZN1001 - Hygienic T-Piece)

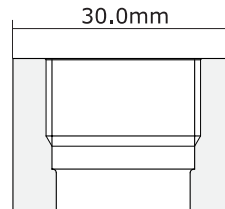

Hygienic weld-on nipple

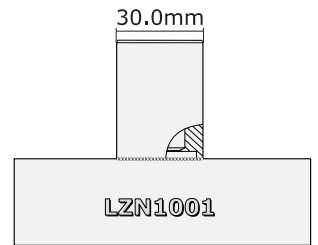

LZN1001: Hygienic T-Piece

M12 CONNECTION

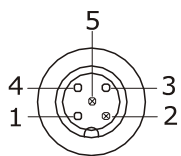

1. +VDC
2. Tx (only with program adapter)
3. GND
4. Rx (only with program adapter)

PC INTERFACE

As standard the KMW-LC can be used directly for the most common liquids. The KMW-LC can be configured via the PC-Interface. With the special software (KlaySoft) the KMW-LC can be set for various switching functions (NC and NO). The delay and the sensitivity can be adjusted to set a suitable switching function for high and low conductive liquids. The latest version of the PC Interface can be downloaded at www.klay.nl. The KMW-LC must be connected as displayed below:

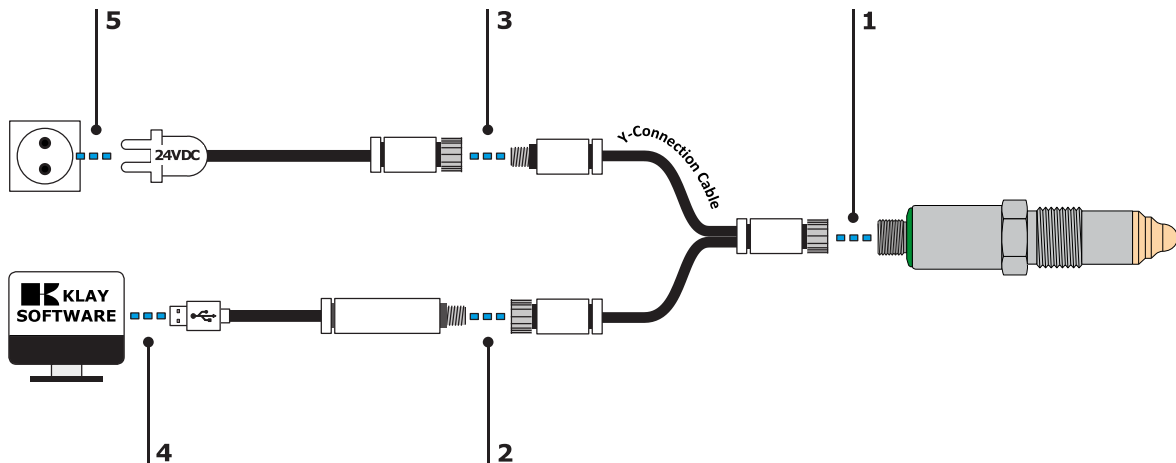

CONNECTION SWITCH AND KLAY SOFTWARE (KLAYSFT)

- Connect the sensor to the Y-Connection Cable (Article No: ST-M12-Y-AD).
- Connect the USB adapter cable to the Y-Connection Cable.
- Connect the Power supply to the Y-Connection Cable.
- Connect the USB connector to the computer (Article No: KMW-PA-M12).
- Connect the 24 VDC Power adaptor.
- Make sure all M12 connectors are connected properly
- For first time use, the PC-Interface (KlaySoft) must be installed, the latest version of the software can be download at www.klay.nl under section Downloads, category Software.
- Start the KlaySoft.

Switch monitoring and trending with PC-USB interface software.

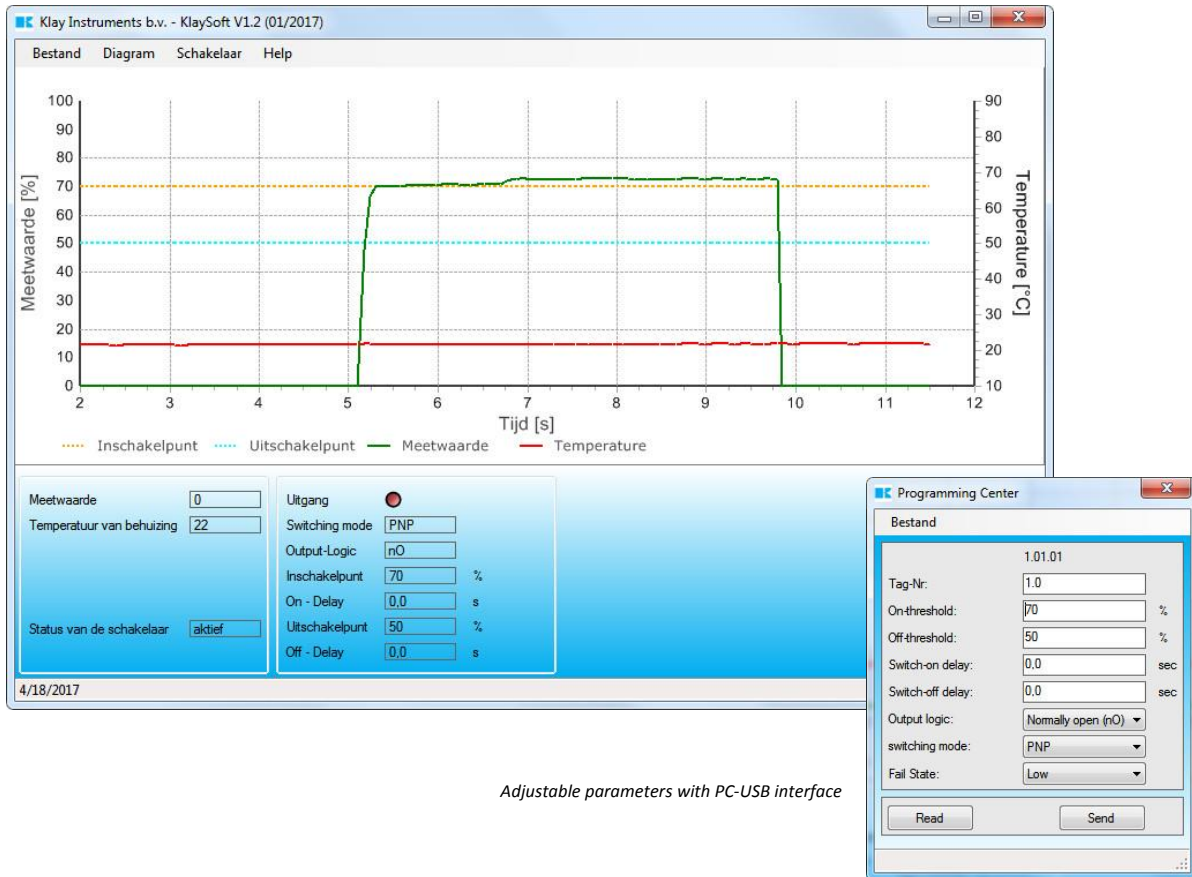

Adjustable parameters with PC-USB interface

LEVEL SWITCH

Type: KMW-LC

½" BSP Connection (Sanitary)

(Must be used with weldon nipple type LZN, Art No: 10662)

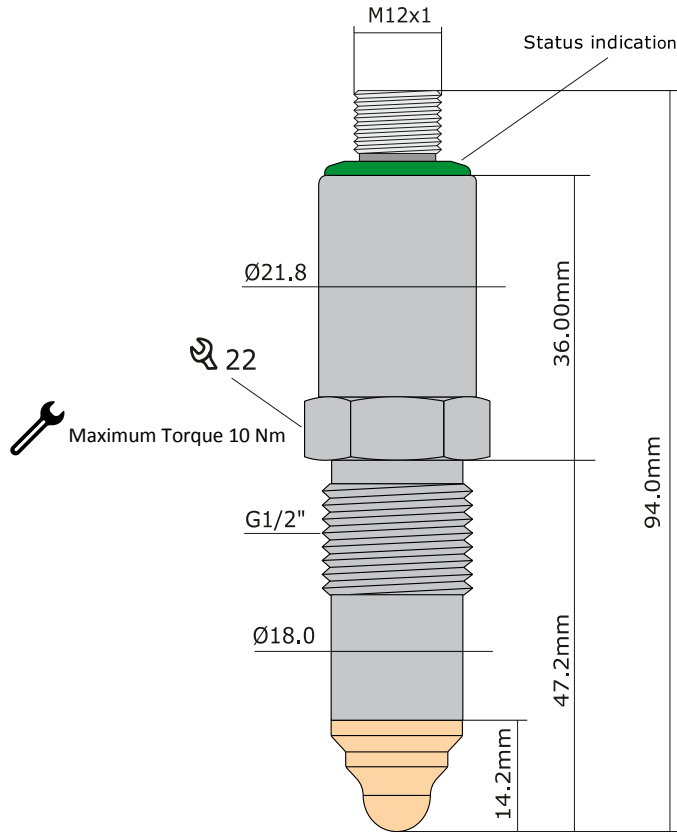

SPECIFICATIONS

Supply	Ub = 24 Vdc +/- 20% (12...32 Vdc)
Permissible load	< 100 mA
Output	PNP, NPN or Push Pull
Switching delay	< 0,3 Seconds
Response time	200 ms
Ambient temperature	-10 till +70°C
Storage temperature	-20 till +70°C
Ingress protection	IP68 / IP69K
Process pressure	Max. 10 bar
Process temperature CIP/SIP cleaning	0 till +100°C 0 till +150°C (30 min) 0 till +130°C (1 hour)

ORDERCODE

KMW-	LC-	
------	-----	--

½" BSP (Standard)		
1" BSP	To exchange 'tuning fork' level switch	S
Milk coupling (DIN 11851)	DN25, DN40, DN50	M
Varivent	X4	X4